



THICK
MATERIAL
SEWING
EXPERT

厚料缝制专家



工缝针车设备有限公司

Gognfeng Needle Car Equipment Co., Ltd.

地址/Add: 广东省东莞市寮步镇凫山管理区凫西路102号二楼

No.102 Fuxi Road of 2nd Floor, Fushan Management District,
Liaobu, Dongguan, Guangdong, China.

联系人/Contacts: 韩水林/Han Shuilin 136 8491 2620 (微信同号)

电话&传真/Tel&Fax: 0769-8321 2620 商务QQ: 1123995293



请扫二维码
了解更多产品



一针一线 创造精品

The world's first

全球首创

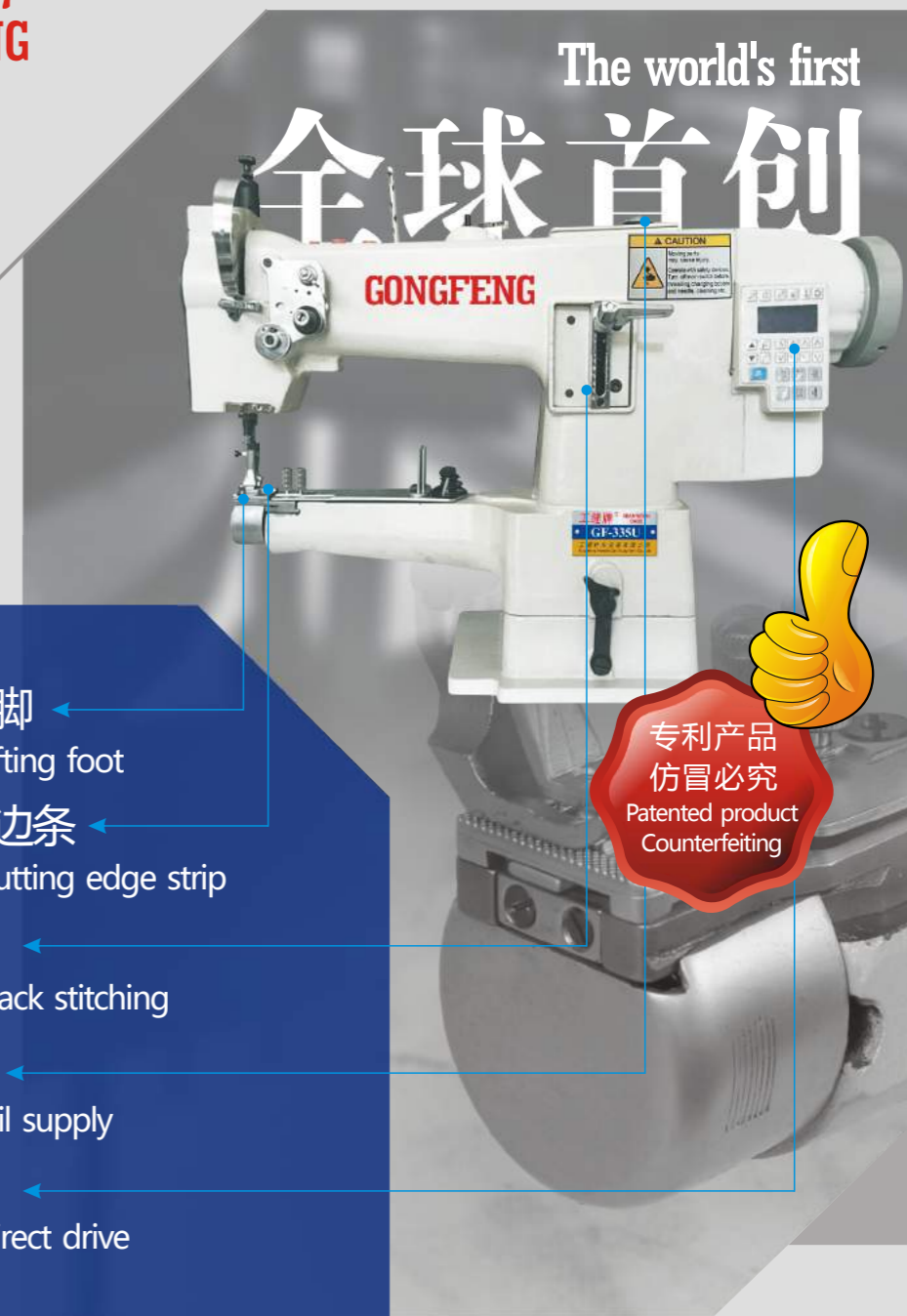

- 自动抬压脚
Automatic lifting foot
- 自动切包边条
Automatic cutting edge strip
- 自动倒缝
Automatic back stitching
- 自动供油
Automatic oil supply
- 电脑直驱
Computer direct drive

专利产品
仿冒必究
Patented product
Counterfeiting

THICK MATERIAL
SEWING EXPERT
厚料缝制专家

生产厂家 承接贴牌
Manufacturer Undertake OEM

工缝针车设备有限公司

Gognfeng Needle Car Equipment Co., Ltd.



Introduction 公司简介

工缝针车设备有限公司是一家专业从事设计、制造和销售工业缝纫机的企业。凭借对厚料机市场精准定位和完善的技术开发及诚信的服务，使得公司得到快速的发展壮大，从最初名不见经传的小厂，到如今成为行业内家喻户晓的知名品牌。本公司生产的工缝牌GF系列产品，经过市场的洗礼，日臻成熟，得到用户的一致好评和信赖，工缝的成长离不开新老顾客的支持和厚爱，我们将一如既往地为客户创造性能稳、价格优的产品。

Gongfeng sewing machine equipment co., LTD. Is an enterprise specializing in designing, manufacturing and selling industrial sewing machines. Relying on precise market positioning of thick-material machine and perfect technology development and honest services, the company has been rapidly developing and expanding, from a small factory that was not known by much at first to a well-known brand in the industry. The GF series products produced by our company have been increasingly mature after the baptism of the market, and have been praised and trusted by the users. The growth of our company is inseparable from the support and love of new and old customers. We will, as always, create products with stable performance and excellent price for customers.

您的满意就是我们的追求！

Your satisfaction is our pursuit!

企业开拓：顺应当下全球发展需要，在国内外各大制鞋、帽、手袋、箱包、玩具、体育用品等省市发展一线产品代理商。

经营理念：聚才兴业、共荣，追求完美，超越是我们的方向。诚信立足，创新致远，突破蜕变。

企业信奉：以科技保质量，以服务赢信赖。

企业创新：公司建立了集开发、设计、生产、检测等完整技术体系。创新是发展的不竭动力。

企业价值：为顾客创造价值，为员工创造条件，为社会创造效益。服务于国内外客户，力争与新老客户携手共进，取得更大的成就！

众多国内首创：电脑供油335、大针距335 360度回旋针织机等。

Enterprise development: according to the current global development needs, develop the agents of first-line products in various provinces and cities, such as shoes, hats, handbags, suitcases, toys and sporting goods, at home and abroad.

Business philosophy: get together to do business, common prosperity, the pursuit of perfection, beyond is our direction. Integrity based, innovation zhi yuan, breakthrough change.

The enterprise believes: by the science and technology guarantees the quality, by the service wins the trust.

Enterprise innovation: the company has established a complete technical system including development, design, production and testing. Innovation is an inexhaustible driving force for development.

Enterprise value: create value for customers, create conditions for employees, and create benefits for society. Serve customers at home and abroad, and strive to join hands with new and old customers, and achieve greater achievements!

Many domestic initiatives: computer oil supply 335, large needle distance 335, 360 degrees roundabout knitting machines.

一针一线 创造精品
One stitch and one line

本产品已获批：**1项发明专利**
1项外观专利、3项实用专利

This product has been approved: 1 invention patent,
1 appearance patent and 3 utility patents



GF-335 (直驱自动供油/大梭/小梭)

筒式水平送料直驱电脑包边车

Cylinder Bed Horizontal Feed Binding Integrated Computer Sewing Machine

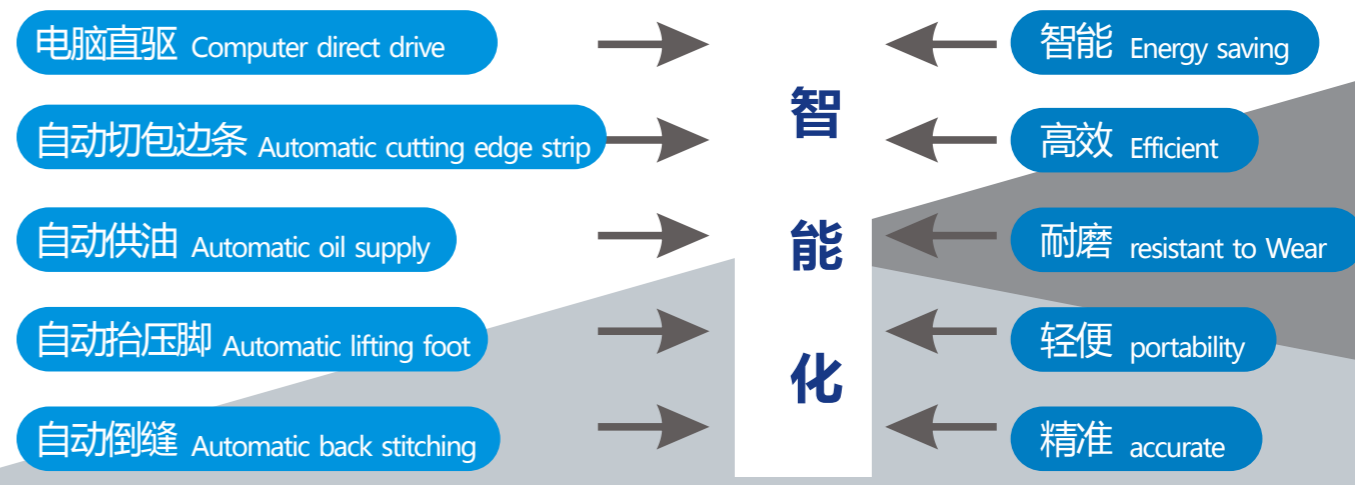

产品说明 / Product Manual

- | | |
|--------------------------------|------------------------------------------------------------------------------------------------|
| 1、圆筒直径46MM 小型或筒状物品易于操作。 | 1, Cylindrical diameter 46MM, small or cylindrical items easy to operate. |
| 2、包边筒（喇叭）同步送料，车缝效果平顺美观。 | 2, Package edge tube (speaker) synchronous feeding, sewing effect smooth and beautiful. |
| 3、采用优良的结构设计，可以灵活的配合多样化物料车缝。 | 3, The use of excellent structural design, can be flexible with a variety of materials sewing. |
| 4、适用于鞋类，布袋，玩具，体育用品，制帽等各种物料的车缝。 | 4, Applicable to footwear, bags, toys, sporting goods, cap and other materials of the sewing. |

技术参数 / Technical Parameters

型号 Model	转速 S.P.M Sewing speed	针迹长度 Stitch length	压脚高度 Presser foot lift	机针型号 Needle model	大梭线芯 Large shuttle core diameter
GF-335	2200r/min	0~7mm	15mm	DP x 17	26mm

GF-335 (大梭/小梭)

筒式水平送料直驱式包边车

Cylinder Bed Horizontal Feed Binding Direct drive Sewing Machine



针对运动物品材料特别设计
Specially designed for sports article materials

例Ex :

潜水料 : 弹性高
diving material high elasticity

棉鞋 : 超厚
cotton shoes super thick

礼品盒 : 超硬
gift box super hard



产品说明 / Product Manual

- 1、圆筒直径46MM 小型或筒状物品易于操作。
- 2、包边筒（喇叭）同步送料，车缝效果平顺美观。
- 3、采用优良的结构设计，可以灵活的配合多样化物料车缝。
- 4、适用于鞋类，布袋，玩具，运动用品，制帽等各种物料的车缝。

- 1、Cylindrical diameter 46MM, small or cylindrical items easy to operate.
- 2、Package edge tube (speaker) synchronous feeding, sewing effect smooth and beautiful.
- 3、The use of excellent structural design, can be flexible with a variety of materials sewing.
- 4、Applicable to footwear, bags, toys, sporting goods, cap and other materials of the sewing.

技术参数 / Technical Parameters

型号 Model	转速 Sewing speed	针轨长度 Stitch length	压脚高度 Presser foot lift	机针型号 Needle model	线芯直径 Core diameter
GF-335	2200r/min	0~7mm	15mm	DP x 17	21mm

GF-335 (大梭/小梭)

筒式水平送料包边车

Cylinder Bed Horizontal Feed Binding Sewing Machine



GLC纳米非晶自润滑涂层
具有不生锈、耐磨等特点。



耐磨涂层
Self-lubrication coating

镀层硬度/HV : 2000-2500HV

镀层颜色/Color : 黑色 Black

镀层厚度/Thick : 1-3um

摩擦系数/f : 0.05-0.09(钢的摩擦系数为0.7)

磨损率: 在空气环境中, 磨损率为 $5 \times 10^{-18} \text{m}^3/\text{Nm}$

镀层在水中或潮湿环境下的工作性能更加出色, 镀层表面的承载能力大。



大梭Big bobbin 小梭Small bobbin

产品说明 / Product Manual

- 1、圆筒直径46MM 小型或筒状物品易于操作。
- 2、包边筒（喇叭）同步送料，车缝效果平顺美观。
- 3、采用优良的结构设计，可以灵活的配合多样化物料车缝。
- 4、适用于鞋类，布袋，玩具，运动用品，制帽等各种物料的车缝。

- 1、Cylindrical diameter 46MM, small or cylindrical items easy to operate.
- 2、Package edge tube (speaker) synchronous feeding, sewing effect smooth and beautiful.
- 3、The use of excellent structural design, can be flexible with a variety of materials sewing.
- 4、Applicable to footwear, bags, toys, sporting goods, cap and other materials of the sewing.

技术参数 / Technical Parameters

型号 Model	转速 Sewing speed	针轨长度 Stitch length	压脚高度 Presser foot lift	机针型号 Needle model	线芯直径 Core diameter
GF-335	2200r/min	0~7mm	15mm	DP x 17	21mm
GF-335带脚控	2200r/min	0~7mm	15mm	DP x 17	21mm

GF-6030G/5030G/4030G

直驱式电脑花样机

Direct Drive Computer Procedural Pattern Sewing Machine

缝纫范围：600*300mm/500*300mm/400*300mm

2,700针/分钟
2,700 needles / minute

强劲穿透力
Strong penetration

耗电低
Low power consumption

缝纫精美线迹
Delicate sewing stitching

全回旋2倍旋梭
Full swing 2 times hook

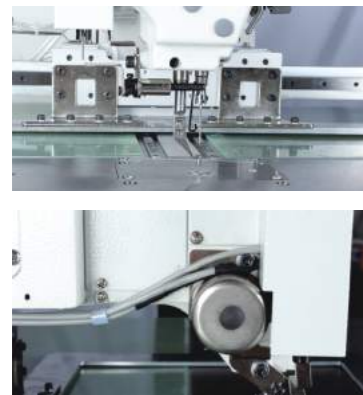

技术参数 / Technical Parameters

机器型号	Machine type	GF-6030G	GF-5030G	GF-4030G
缝纫范围	Sewing range	600mm*300mm	500mm*300mm	400mm*300mm
缝纫形式	Sewing form	单针平缝 Single-needle flat seam		
旋梭种类	Rotary shuttle type	全回旋2倍旋梭 Full swing 2 times hook		
送料方式	Feeding method	间歇或连续送料(可切换) Intermittent or continuous feeding (switchable)		
线迹缝距	Stitch spacing	0.05mm至12.7mm		
最大针数	Maximum number of stitches	20,000/花样 Pattern		
外压脚提升量	External pressure foot lift amount	25mm		
外压脚方式	External pressure foot method	气动式 Pneumatic		
中压脚方式	Medium pressure foot method	伺服驱动 Servo drive		
中压脚提升量	Medium pressure foot lift	15mm		
中压脚行程	Medium pressure foot stroke	4-10mm		
电源	Power	200-240V,单相/三相、110-120V单相和380-415V三相(需选配单元) 200-240V, single-phase/three-phase, 110-120V single-phase and 380-415V three-phase (requires optional unit)		

GF-3020

激光开袋机

Laser Bag Opening Machine

激光开袋
Laser Bag Opening



产品说明 / Product Manual

- 1、降低对熟练工的依赖，生手一学就会。
- 2、提高效率，是原始人工的3倍以上效率。一天可开袋生产800-1100条。
- 3、适用于各种针织、梭织、弹力面料。
- 4、红外线自动对位，无需画位，节省人工，做出的样片，个个一样标准。
- 5、采用了独立的驱动马达。由于不受缝制速度的影响，切刀的切布质量有了明显提高，实现完美的切口，另外，对切刀形状的改良有效防止了切刀弯曲现象的发生，提高了对弹性面料的裁切质量。

- 1, Reduce the dependence on skilled workers.
- 2, To increase efficiency is more than three times the efficiency of the original manpower. One day can open bag production 800-1100.
- 3, Suitable for all kinds of knitting, woven, stretch fabrics.
- 4, Infrared automatic alignment, no need to draw bits, save labor, make samples, all the same standard.
- 5, Using a separate drive motor. Because it is not affected by the sewing speed, the cutting quality of the cutting knife has been significantly improved to achieve a perfect incision. In addition, the improvement of the shape of the cutting knife has effectively prevented the bending phenomenon of the cutting knife and improved the cutting of the elastic fabric. Cut quality.

技术参数 / Technical Parameters

型号	转速	针轨长度	压脚形式	机针型号	使用梭床	主轴电机
Model	Sewing speed	Stitch length	Presser foot form	Needle model	Using a shuttle bed	Spindle motor
GF-3020激光开袋	2500r/min	0.1-12.7mm	气动式 Pneumatic	DP x 17#18	2倍旋梭 2 times hook	直驱式伺服电机 Direct-drive servo motor

GF-8B (直驱自动供油/大梭可配)

筒式综合送料直驱电脑高车

Compound Feed Integrated Computer Sewing Machine

产品说明 / Product Manual

- 1、专利设计，直驱一体机；
- 2、倒缝结构专利，高效省力；
- 3、可选装气动抬压脚、倒缝装置；
- 4、自动供油、自动绕线、上下定针功能；
- 5、机电一体化伺服电控，低能耗，低噪音，低震动，省电64%。

- 1, patent design, direct drive one machine;
- 2, inverted structure patents, efficient and labor-saving;
- 3, optional pneumatic lifting presser foot, reverse sewing device;
- 4, automatic oil supply, automatic winding, up and down fixed function;
- 5, electro mechanical integration servo control, low energy consumption, low noise, low vibration, saving 64%.



GF-8BL (加长型)

加长型筒式综合送料标准旋梭高车

Long Arm Compound Feed Cylinder Bed Standard Hook Sewing Machine

产品说明 / Product Manual

- 1、本机设计采用小筒形缝台，综合送料，同步式移动包边装置。
- 2、机器外观设计新颖，操作调节方便，缝纫线迹美观均衡，工作效率出众。
- 3、由于小直径筒形缝台，广泛应用于各类皮具、皮革服装生产、制鞋、座椅垫子加工。
- 4、适用于衣服、包袋、皮具的缝纫及制鞋、箱包、坐垫生产中的滚边工序。

- 1, This machine is specially designed for luggage manufacturing cylindrical thick flat sewing machine, solid structure, modeling is more.
- 2, Machine appearance design is novel, convenient operation and adjustment, the equilibrium of sewing thread, the work efficiency.
- 3, Due to the small diameter cylindrical seaming machine, widely used in production of all kinds of leather clothing, shoes, seat cushion for processing.
- 4, Suitable for sewing leather wear, bags, leather goods, shoes, seat cushion, etc. in the piping process.



技术参数 / Technical Parameters

型号 Model	转速 S.P.M Sewing speed	针迹长度 Stitch length	压脚高度 Presser foot lift	机针型号 Needle model	筒径 Cylindrical diameter
GF-8B精品供油直驱/大梭可配	2200r/min	0~7.5mm	14mm	DP x 17	65mm
GF-8B(加长型)	2200r/min	0~7.5mm	14mm	DP x 17	65mm

GF-246 (直驱自动供油)

筒式综合送料直驱电脑小嘴高车

Compound Feed Integrated Computer Sewing Machine

产品说明 / Product Manual

- 1、专利设计，直驱一体机；
- 2、倒缝结构专利，高效省力；
- 3、可选装气动抬压脚、倒缝装置；
- 4、自动供油、自动绕线、上下定针功能；
- 5、机电一体化伺服电控，低能耗，低噪音，低震动，省电64%。

- 1, patent design, direct drive one machine;
- 2, inverted structure patents, efficient and labor-saving;
- 3, optional pneumatic lifting presser foot, reverse sewing device;
- 4, automatic oil supply, automatic winding, up and down fixed function;
- 5, electro mechanical integration servo control, low energy consumption, low noise, low vibration, saving 64%.



GF-244/245/246 (精品供油)

筒式综合送料自动供油大梭小嘴高车

Compound Feed Auto Oil large Hook Sewing Machine

产品说明 / Product Manual

- 1、本机设计采用小筒形缝台，综合送料，同步式移动包边装置。
- 2、机器外观设计新颖，操作调节方便，缝纫线迹美观均衡，工作效率出众。
- 3、由于小直径筒形缝台，广泛应用于各类皮具、皮革服装生产、制鞋、座椅垫子加工。
- 4、适用于衣服、包袋、皮具的缝纫及制鞋、箱包、坐垫生产中的滚边工序。

- 1, This machine is specially designed for luggage manufacturing cylindrical thick flat sewing machine, solid structure, modeling is more.
- 2, Machine appearance design is novel, convenient operation and adjustment, the equilibrium of sewing thread, the work efficiency.
- 3, Due to the small diameter cylindrical seaming machine, widely used in production of all kinds of leather clothing, shoes, seat cushion for processing.
- 4, Suitable for sewing leather wear, bags, leather goods, shoes, seat cushion, etc. in the piping process.



技术参数 / Technical Parameters

型号 Model	转速 S.P.M Sewing speed	针迹长度 Stitch length	压脚高度 Presser foot lift	机针型号 Needle model	筒径 Cylindrical diameter
GF-246(直驱自动供油)	2200r/min	0~9mm	15mm	DP x 17	50mm
GF-244/245/246(精品供油)	2200r/min	0~9mm	15mm	DP x 17	50mm

GF-341/341加长 筒式综合送料自动供油大嘴高车

Compound Feed Auto Oil Sewing Machine



GONGFENG

860mm

(双针加长型)

Double needle Long Arm

自动供油
Automatic refueling

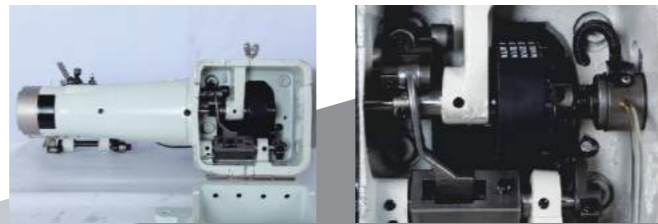

产品说明 / Product Manual

1. 采用新款牙架，双倍大旋梭和梭仔，台湾产斜纹齿轮，镶铜套的梭床座，标准牛角分线勾等配件。专为箱包制造设计的筒式厚料平缝机，机构坚实，造型新颖。
2. 采用滑杆挑线，构成双线锁式线迹，上下轴用同步齿型带传动。
3. 压脚、送布牙、机针同步送料，杠杆式针距调节机构。
4. 高压脚行程，高压脚提间隙和大的线迹长度，配合筒形缝台。

1. Using new tooth rack, large double hook and the hook, taiwan twill gear, copper inlay nest bobbin sleeve, a standard hook horn sub-line and other accessories. Designed for the manufacture of luggage box thick material sewing machine, solid institutions, innovative style.
2. Using a slider to take the line, constitute a two-lane lock stitch, upper and lower shaft with synchronous tooth belt drive.
3. Pressure foot, send cloth teeth, needle synchronous feeding, lever-type needle pitch adjustment mechanism.
4. High-pressure foot travel, high-pressure foot lift and large stitch length, with the cylinder slot.

技术参数 / Technical Parameters

型号 Model	转速 Sewing speed	针距长度 Stitch length	压脚高度 Presser foot lift	机针型号 Needle model	筒径 Cylindrical diameter
GF-341(加长)	2200r/min	0~9mm	14mm	DP x 17	70mm
GF-341(自动供油)	2200r/min	0~9mm	14mm	DP x 17	70mm

GF-1341 (自动供油) 筒式综合送料自动供油大嘴高车

Compound Feed Auto Oil Sewing Machine



大针距 11mm
Large needle distance 11mm

产品说明 / Product Manual

1. 采用新款牙架，双倍大旋梭和梭仔，台湾产斜纹齿轮，镶铜套的梭床座，标准牛角分线勾等配件。专为箱包制造设计的筒式厚料平缝机，机构坚实，造型新颖。
2. 采用滑杆挑线，构成双线锁式线迹，上下轴用同步齿型带传动。
3. 压脚、送布牙、机针同步送料，杠杆式针距调节机构。
4. 高压脚行程，高压脚提间隙和大的线迹长度，配合筒形缝台。

1. Using new tooth rack, large double hook and the hook, taiwan twill gear, copper inlay nest bobbin sleeve, a standard hook horn sub-line and other accessories. Designed for the manufacture of luggage box thick material sewing machine, solid institutions, innovative style.
2. Using a slider to take the line, constitute a two-lane lock stitch, upper and lower shaft with synchronous tooth belt drive.
3. Pressure foot, send cloth teeth, needle synchronous feeding, lever-type needle pitch adjustment mechanism.
4. High-pressure foot travel, high-pressure foot lift and large stitch length, with the cylinder slot.



GF- 灯罩机

筒式综合送料大梭小嘴高车

Compound Feed large Hook Sewing Machine

产品说明 / Product Manual

1. 本机系列属于特种机，专为特殊用品设计，如：灯罩、帐篷、长型口袋、箱包、座垫、运动用品，及需模向车缝物品等。
2. 采用滚轮综合式送料，使硬、软、厚、薄料均可缝制，使线迹更加美观。
3. 本产品采用锁式大线芯旋梭，减少换线时间，提高效率，让线迹环环相扣，不掉线，稳定、牢固。
4. 可根据客户需求订做：加长、加高、圆型、方型、压脚送料，自动抬压脚、自动倒缝等。

1. This machine series belongs to the sewing machine, specially designs for the special supplies, such as: the lamp shade, the tent, the long type pocket, the box bag, the seat cushion, the movement supplies, and needs the mold to sewing goods and so on.
2. By adopting the integrated feeding of roller, hard, soft, thick and thin materials can be sewn to make the thread trace more beautiful.
3. This product adopts the lock type large-core rotating shuttle, which can reduce the wire changing time, improve the efficiency, and make the line trace interlocked, not dropped, stable and firm.
4. Can be customized according to customer requirements: lengthening, heightening, circular, square, presser foot feed, automatic presser foot, automatic inverted seam, and so on.



技术参数 / Technical Parameters

型号 Model	转速 Sewing speed	针距长度 Stitch length	压脚高度 Presser foot lift	机针型号 Needle model	筒径 Cylindrical diameter
GF-1341(自动供油)	2200r/min	0~11mm	15mm	DP x 17	70mm
GF-灯罩机	2200r/min	0~11mm	15mm	DP x 17	70mm

GF-360

单针360°旋转高头车

360° rotation single needle post bed sewing machine

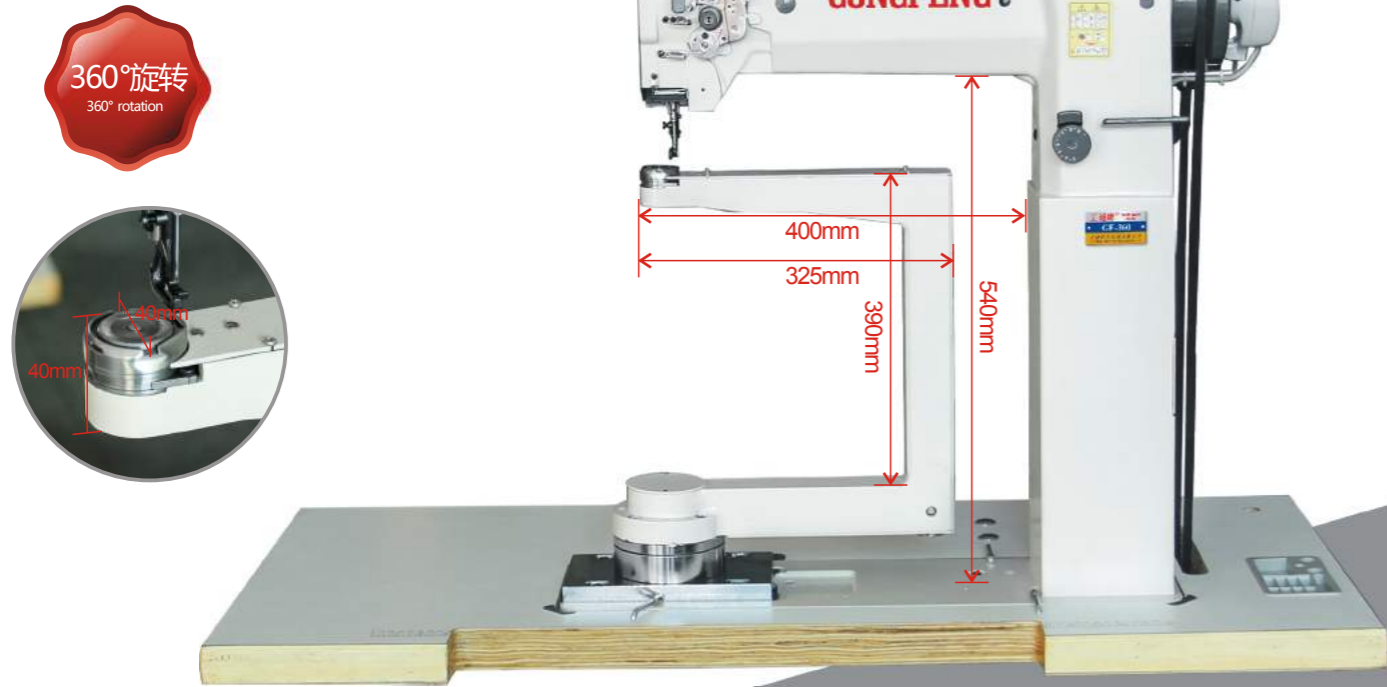

产品说明 / Product Manual

- 1、本机可以360度旋转车，对于筒状物，外形特殊的物品有很强的优势，适合厚料，皮革等材料的箱包，鞋材的车缝。
- 2、采用新款牙架，双倍大旋梭和梭子，台湾产斜纹齿轮，镶铜套的梭床座，标准牛角分线勾等配件。专为箱包制造设计的筒式厚料平缝机，机构坚实，造型新颖。
- 3、采用滑杆挑线，构成双线锁式线迹，上下轴用同步齿型带传动。
- 4、压脚、送布牙、机针同步送料，杠杆式针距调节机构。
- 5、高压脚行程，高压脚起间隙和大的线迹长度，配合筒形缝台。

1. This machine can rotate the car 360 degrees. It has a strong advantage for the special shape of the tube. It is suitable for bags of thick materials, leather and other materials, and sewing of shoe materials.
2. Using new tooth rack, large double hook and the hook, taiwan twill gear, copper inlay nest bobbin sleeve, a standard hook horn sub-line and other accessories. Designed for the manufacture of luggage box thick material sewing machine, solid institutions, innovative style.
3. Using a slider to take the line, constitute a two-lane lock stitch, upper and lower shaft with synchronous tooth belt drive.
4. Pressure foot, send cloth teeth, needle synchronous feeding, lever-type needle pitch adjustment mechanism.
5. High-pressure foot travel, high-pressure foot lift and large stitch length, with the cylinder slot.

技术参数 / Technical Parameters

型号 Model	转速 S.P.M Sewing speed	针轨长度 Stitch length	压脚高度 Presser foot lift	机针型号 Needle model	筒径 Cylindrical diameter
GF-360	700r/min	0~6mm	8-15mm	DP x 17	47mm

GF-8365

单针/双针竖长型综合送料高柱车

Single needle / double needle Compound Feed Post Bed Sewing Machine



双针
Double needle



单针小柱
Single needle Small column



产品说明 / Product Manual

- 1、采用三同步综合送料，缝制厚簿物品均匀美观。
- 2、竖长型的釜座设计（釜座高度443mm）。
- 3、特殊小角度的针板，送布牙设计，增加使用方便性。

1. Using three synchronous feeding, sewing thick book items even beautiful.
2. Vertical shell design (kettle height 443mm).
3. Special small angle of the needle plate, send cloth teeth design, increase the ease of use.

技术参数 / Technical Parameters

型号 Model	转速 S.P.M Sewing speed	针轨长度 Stitch length	压脚高度 Presser foot lift	机针型号 Needle model	针数 Needle aumble
GF-8365单针(自动供油)	1600r/min	0~10mm	14mm	DP x 17	单针/Single
GF-8365双针(自动供油)	1600r/min	0~10mm	14mm	DP x 17	双针/Double

GF-4400/4420 双针综合送厚料平缝机

Double-needle Heavy Duty Compound Feed Lockstitch Sewing Machine (Auto Oil)

单针/双针
Single/double needle



GF-6620 加长型双针综合送厚料平缝机

Long Arm Compound Feed Flat Bed Double Needles Sewing Machine (Auto Oil)

380/457mm



产品说明 / Product Manual

- 1、采用大型立式旋梭勾线，滑杆挑线。
- 2、同步齿形带传送柱塞式油泵润滑系统。
- 3、传动轻滑，噪音小，耐用度高。
- 4、可根据客户要求订做：更长更高产品。

- 1, The machine uses a large vertical hook hook line, slider bar thread.
- 2, Synchronous Toothed belt conveyor plunger pump lubrication system.
- 3, Drive light slip, low noise, high durability.
- 4, Can be customized according to customer requirements: longer and higher products.

技术参数 / Technical Parameters

型号 Model	转速 S.P.M Sewing speed	针迹长度 Stitch length	压脚高度 Presser foot lift	机针型号 Needle model	针数 Needle aumble
GF-4420(自动供油)	2000r/min	0~9mm	16mm	DP x 17	双针/Double
GF-6620(自动供油)	2000r/min	0~12mm	15mm	DP x 17	双针/Double

GD-872 (直驱) 直驱双针综合送厚料平缝机

Double-needle Heavy Duty Compound Feed Lockstitch Sewing Machine

直驱
Direct drive



产品说明 / Product Manual

- 1、采用大型立式旋梭勾线，滑杆挑线。
- 2、同步齿形带传送柱塞式油泵润滑系统。
- 3、传动轻滑，噪音小，耐用度高。

技术参数 / Technical Parameters

型号 Model	转速 S.P.M Sewing speed	针迹长度 Stitch length	压脚高度 Presser foot lift	机针型号 Needle model	针数 Needle aumble
GD-872(直驱自动供油)	2000r/min	0~12mm	16mm	DP x 17	双针/Double
GD-872(自动供油)	2000r/min	0~12mm	16mm	DP x 17	双针/Double

GD-872/842/845 双针综合送厚料平缝机

Double-needle Heavy Duty Compound Feed Lockstitch Sewing Machine

自动供油
Automatic refueling



- 1, The machine uses a large vertical hook hook line, slider bar thread.
- 2, Synchronous Toothed belt conveyor plunger pump lubrication system.
- 3, Drive light slip, low noise, high durability.

GF-988

红外线商标专业冷热电脑切带机

Infrared trademark for hot and cold computer cutting machine

GF-100CH

冷热电脑切带机

Hot and cold computer cutting machine

GF-160CH

冷热重型电脑切带机

Hot and cold heavy computer cutting machine

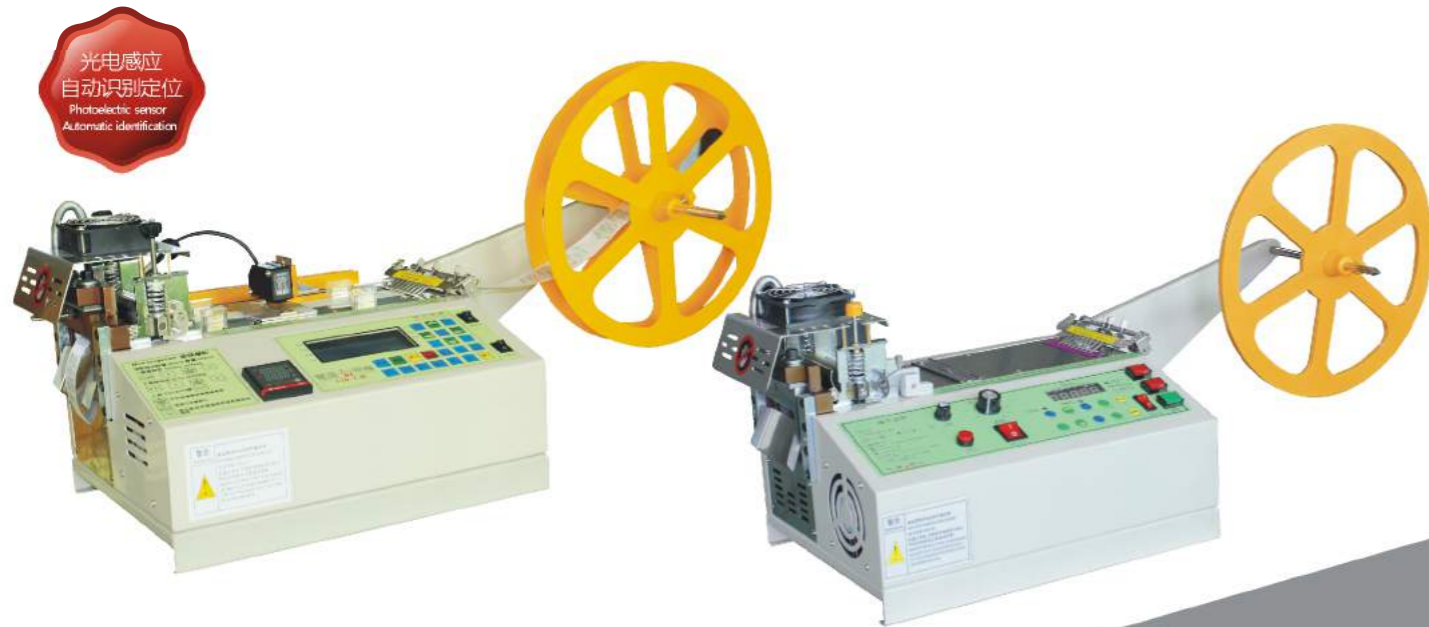

可切不同角度
Different angles can be cut



产品说明 / Product Manual

电脑控制切带机，操作简单，使用方便。设置好程序后机器可多条连续自动裁切，可以根据不同材料采用不同裁切速度，长度和裁切数量可以根据需求设置。可切材质：编织带、松紧带、尼龙织带、彩色腰带、背包带、鞋带等材料。

Computer control tape cutting machine, easy to operate and easy to use. After the program is set, the machine can be cut continuously and automatically. Different cutting speed can be adopted according to different materials, and the length and cutting quantity can be set according to the requirements. Cutting material: woven band, elastic band, nylon ribbon, color belt, strap, LACES and other materials.

技术参数 / Technical Parameters

型号 Model	刀具 Knife tool	电压 Voltage	功率 Power	裁切宽度 Cutting length	裁切长度 Cutting width
GF-988	冷热刀	220V/50HZ	0~48KW	3-95mm	1-99999
GD-100CH	冷热刀	220V/50HZ	0~48KW	3-95mm	1-99999



防打手打扣机

Anti-handling button machine

可切不同角度

Different angles can be cut



最大可切宽度160MM

The maximum cutting width is 160MM



产品说明 / Product Manual

冷热刀电脑切带机既能热切又能冷切，冷刀与热刀可自由切换，一机即可满足用户的多种切带需求。送料由高精度步进电机控制，且可通过操作界面设计误差补偿，可以达到极高的精度。电脑切带机配有机箱和独立挂料架，送料更平稳顺畅。

Cold and hot knife computer strip cutting machine can be hot and hot cutting, cold knife and hot knife can be freely switch, one machine can meet the needs of users. Feeding is controlled by a high-precision stepper motor and can be compensated by the design error through the operation interface to achieve high precision. Computer slitting machine is equipped with case and independent rack, feeding more smooth and smooth.

GF-208A 台式双面上胶机

Desktop double sided gluing machine

双面上胶
可定制尺寸
Double-sided adhesive
can be customized size



GF-208B 立式双面上胶机

Desktop double sided gluing machine



产品说明 / Product Manual

- 1、采用全套进口电机，电路上胶均匀、精度高、不漏胶,90W+1:10变速箱，力度大，可转位机头，使用方便
- 2、适用于手袋上胶用，可自由调整到所需宽度密封式长期运转，不会挥发掉，永不凝固，不必清先机台永远如新，全自动无段安速控制，速度快慢可自由调整。
- 3、一般强力胶、黄胶、粉胶、不干胶均可使用备有回转装置，停止使用时，可回收胶液永不漏胶，上胶量可随意调整。
- 4、本机使用于制鞋，皮革制品业（热熔胶片、鞋用港宝）、文具业（笔记夹文书夹）双面同时上胶及对面、相框运动器材作业使用。

1. It adopts a full set of imported motor, the circuit is evenly glued, high precision, no leakage, 90W+1:10 gearbox, strong force, indexable head, easy to use
2. It is suitable for the glue on the handbag. It can be adjusted freely to the required width and sealed for long-term rotation. It will not evaporate. It will never be doubtful. It is not necessary to clear the machine forever. It is completely automatic and has no automatic speed control. The speed can be adjusted freely.
3. the general super glue, yellow plastic, powder glue, self-adhesive can be used with a rotating device, when the use is stopped, the glue can be recycled without leaking glue, the amount of glue can be adjusted at will.
4. This machine is used in shoemaking, leather products industry (hot melt film, shoe port), stationery industry (notebook folder) double-sided simultaneous gluing and opposite, photo frame sports equipment operation.

GF-430D 电脑套结机

Computer loop tying machine



产品说明 / Product Manual

- 1、作为电子套结机它不仅实现了3200rpm的业务最高缝制速度，还能快速启动或停止。
- 2、通过提高切线速度以及抬压脚操作大幅度缩短了机器的操作循环时间。
- 3、在纵向有效的缝制范围内，可以应对多种套结形状。缝制花格可根据工艺要求自由设定。
- 4、采用了灵活的张力，通过操作控制盘可以设定面线的张力以对应各种缝制条件，数据可以储存以及再使用。
- 5、先进的干式机头化技术，在面部（针杆部、挑线杆部）实现了无油化。彻底消除了缝制品被机油所污染。

1. As an Computer bar tacking machine, it does not only realize the maximum sewing speed of 3200rpm in the industry, but can have quick start or stop. Through improving the thread cutting speed and presser foot operation, it shortens the operation cycle time of the machine in large scale.
2. In the vertical sewing range of 40mm, it can respond to various bar tacking shapes.
3. Applying flexible tensile force, it can set the tensile force of the top stitch through operating the control panel, so as to conform to each sewing condition. The data can be stored and reused.
4. Through advanced dry machine head technology, it can realize oil-free on the surface (needle bar, take-up lever).
5. Thoroughly remove the pollution of engine oil to the sewing products.